



# Bawarrion

**PREMIUM PERFORMANCE PARTS**

## ***X-TENDER WHEEL ARCH EXTENDERS FOR JEEP WRANGLER JLU/JT X-TENDER RADLAUFVERBREITERUNGEN FÜR JEEP WRANGLER JLU/JT***

***WIREMPFEHLEN DIE ANLEITUNG VOR DEM ANBAU KOMPLETT ZU LESEN !***

*Um eine qualitativ hochwertige Installation zu gewährleisten, empfehlen wir diese Anleitung gründlich zu lesen bevor mit den Arbeiten begonnen wird. Diese Anleitung setzt ein gewisses Maß an mechanischen Fähigkeiten voraus.*

***PLEASE READ BEFORE YOU START!***

*To guarantee a quality installation, we recommend reading these instructions thoroughly before beginning any work. These instructions assume a certain amount of mechanical ability.*









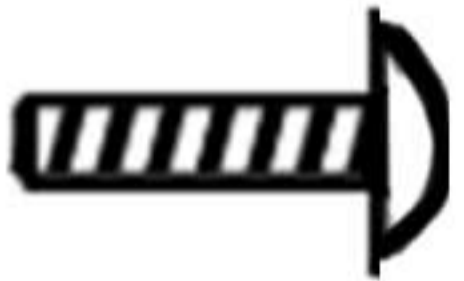

# REQUIRED TOOLS AND MATERIAL

## BENÖTIGTES WERKZEUG UND MATERIAL

- A**  **6x** 6x16Tx30
- B**  **4x** M6x30 SW10
- C**  **4x** M6 (Bolt / Mutter)
- D**  **48x** M6x20

**48x**  
**Rivet nut**  
Einziehmutter

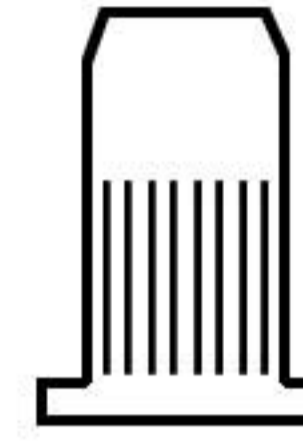

**Adhesive foam tape**  
Klebeband  
(3M, Moos-Gummiartig)

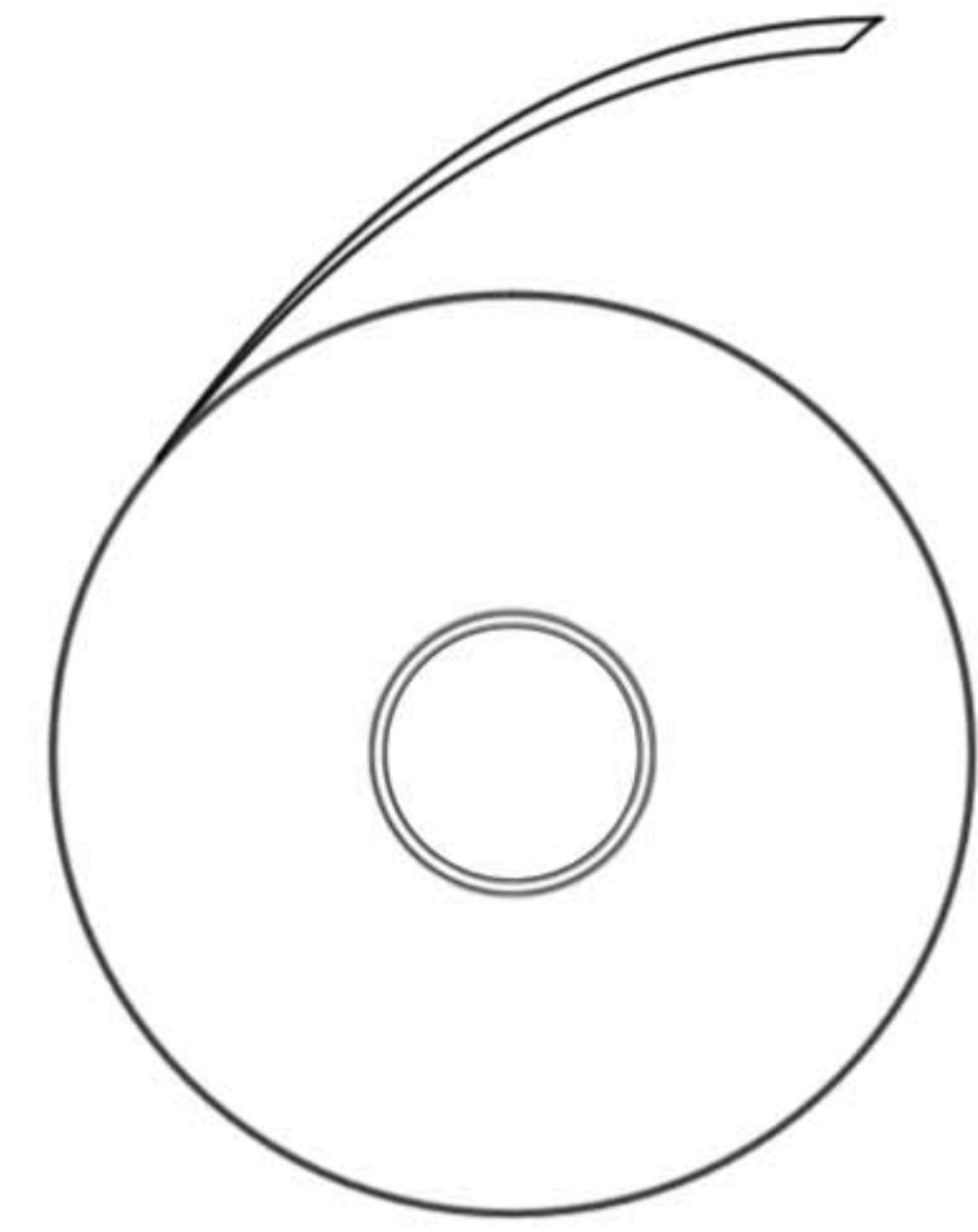

**Screwdriver**  
Schraubendreher



**Wrench set**  
Schlüssel satz



**Rivet nut pliers**  
Nietmutterzange



**Cordless screw driver**  
Akku-Schrauber

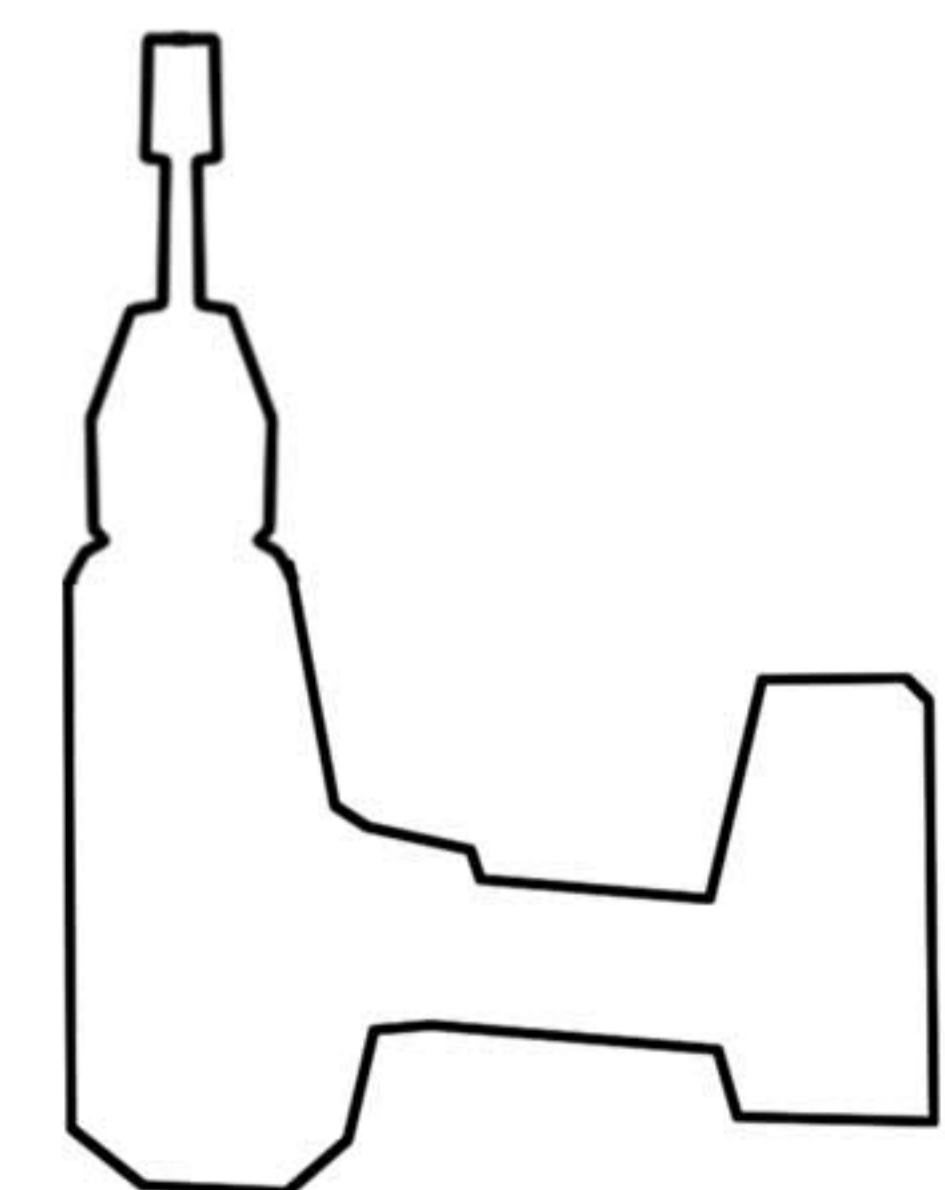

**Pin punch**  
Stiftstanze



**Pneumatic saw**  
Luftdruckluftsäge



**Grinder**  
Luftdruckschleifer



**Clip remover**  
Clipheber



**Rubber hammer**  
Gummi Hammer

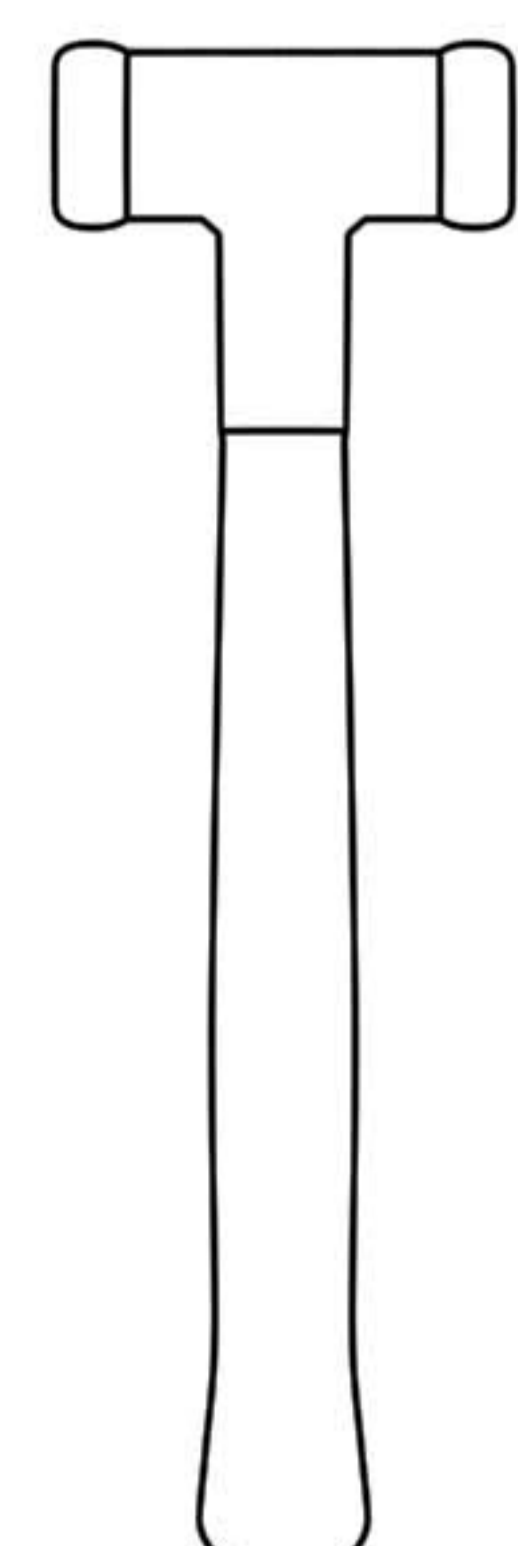





# CONTENT INHALT



**JLU**



**JT**







# UNBOXING AND NEEDED TOOLS AUSPACKUNG UND NOTWENDIGER WERKZEUG

**JLU**

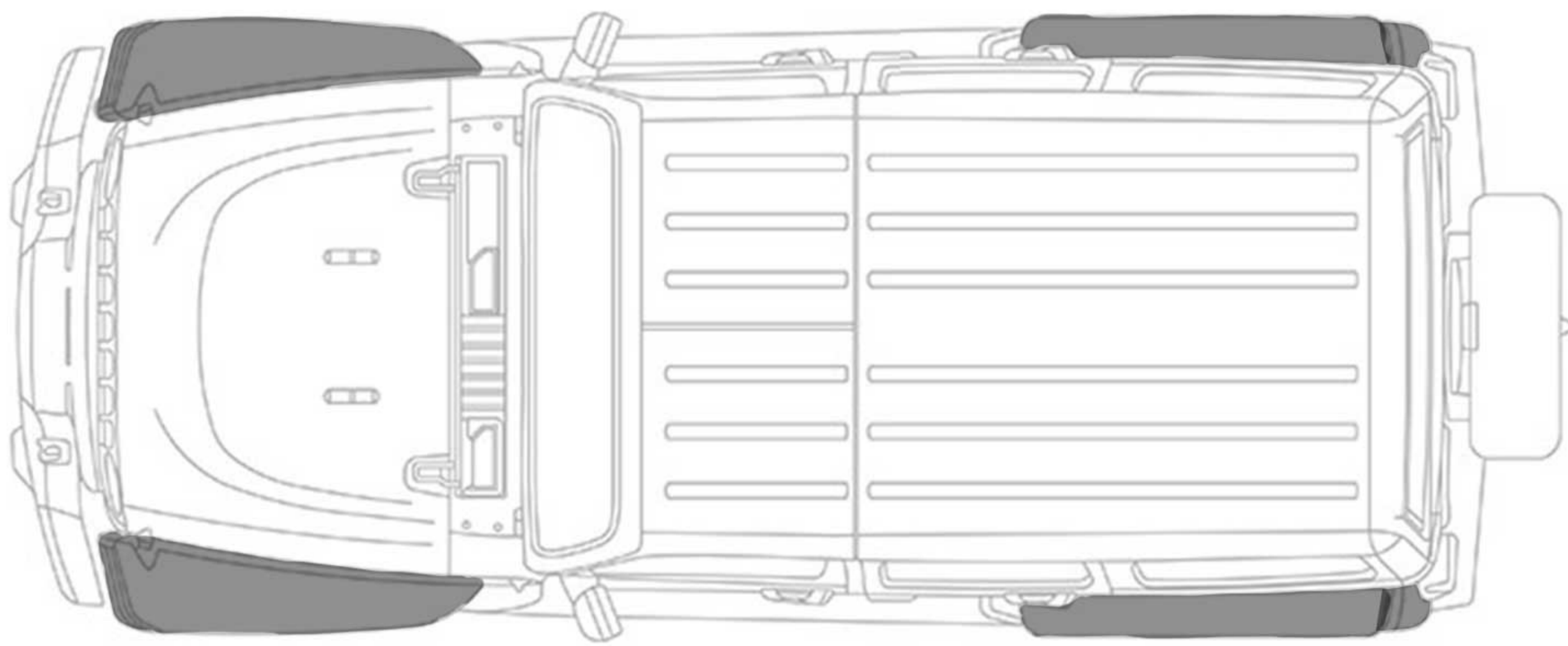
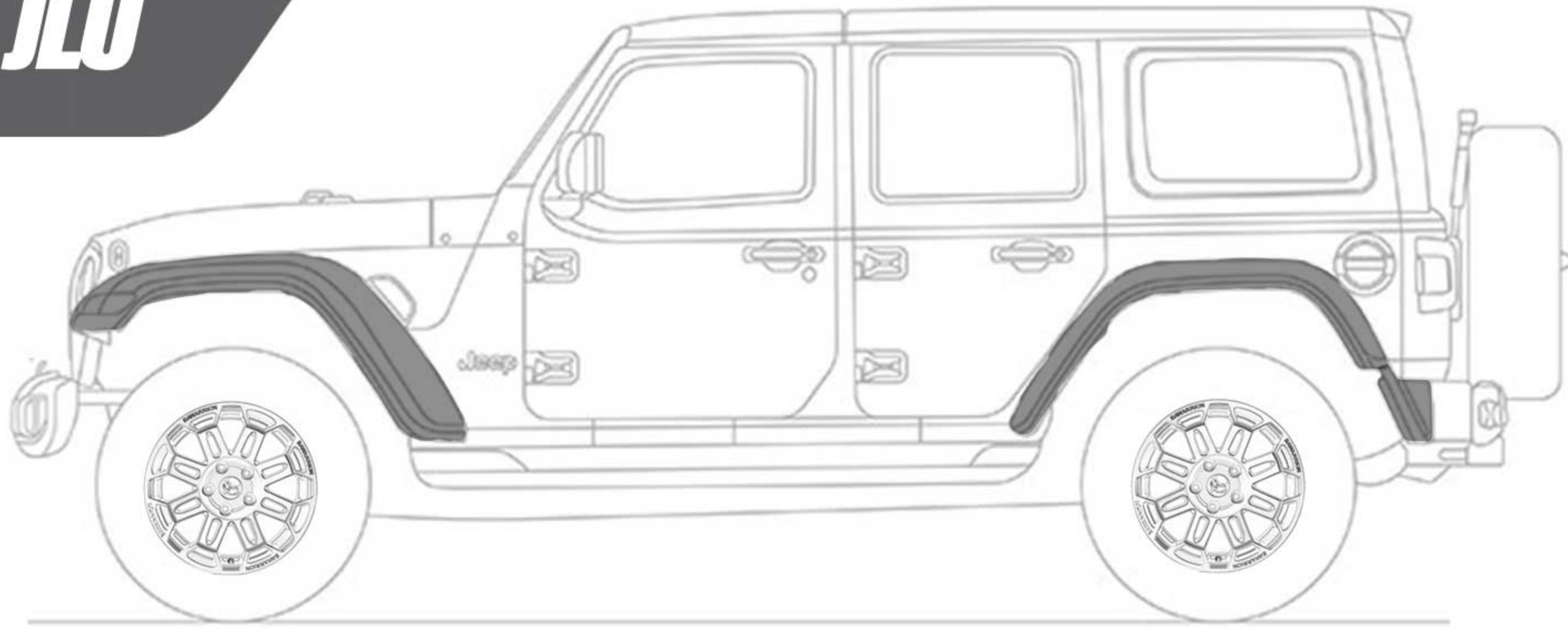

**JT**

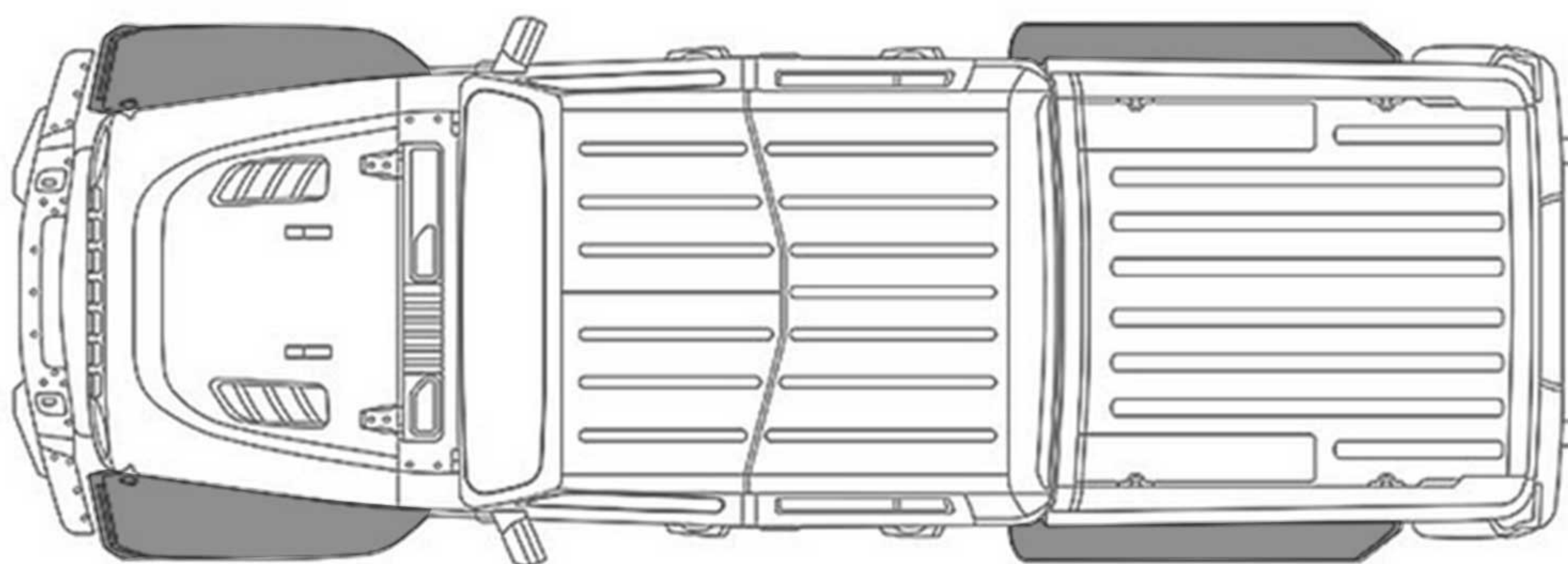
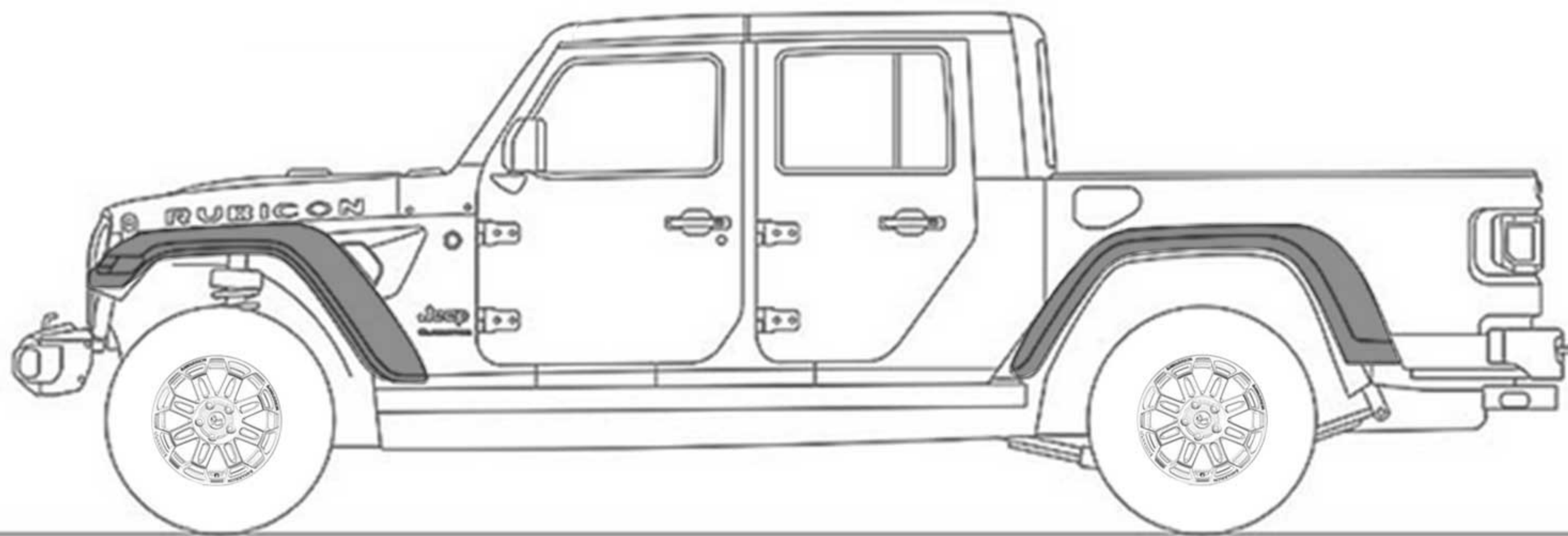





# REMOVING STOCK WHEEL ARCHES ABBAU DER OEM KOTFLÜGELN

1.

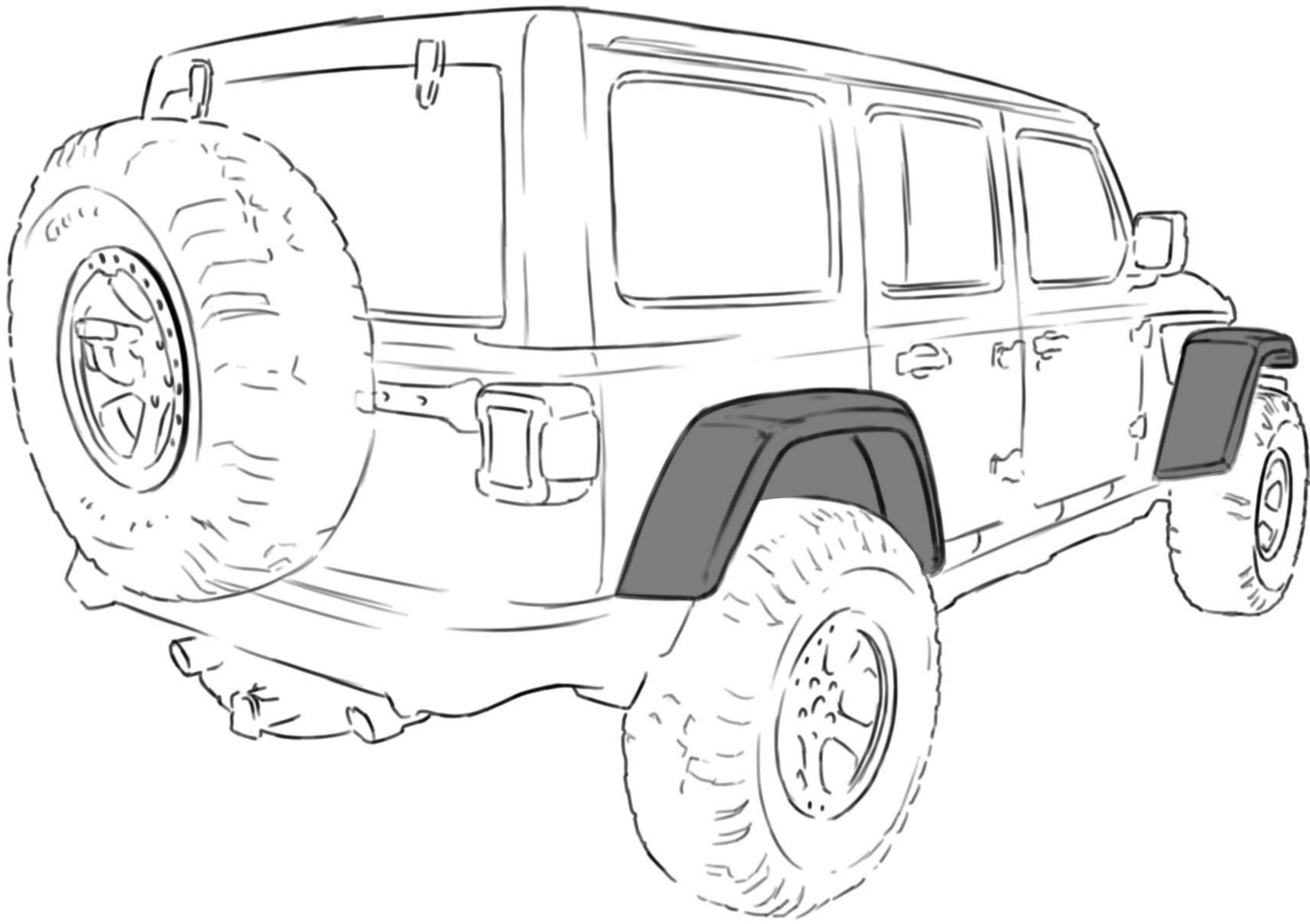

2.

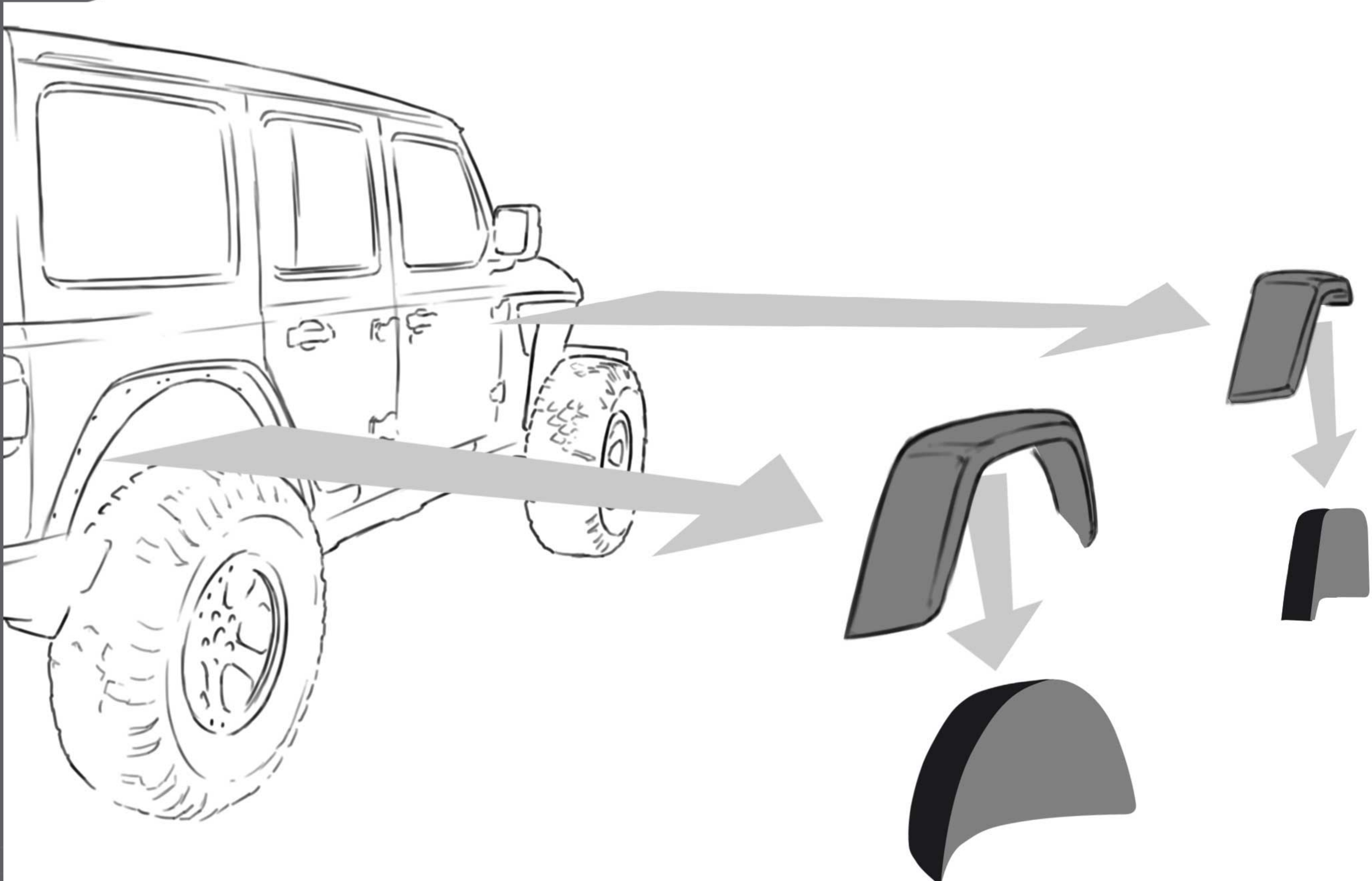



3.

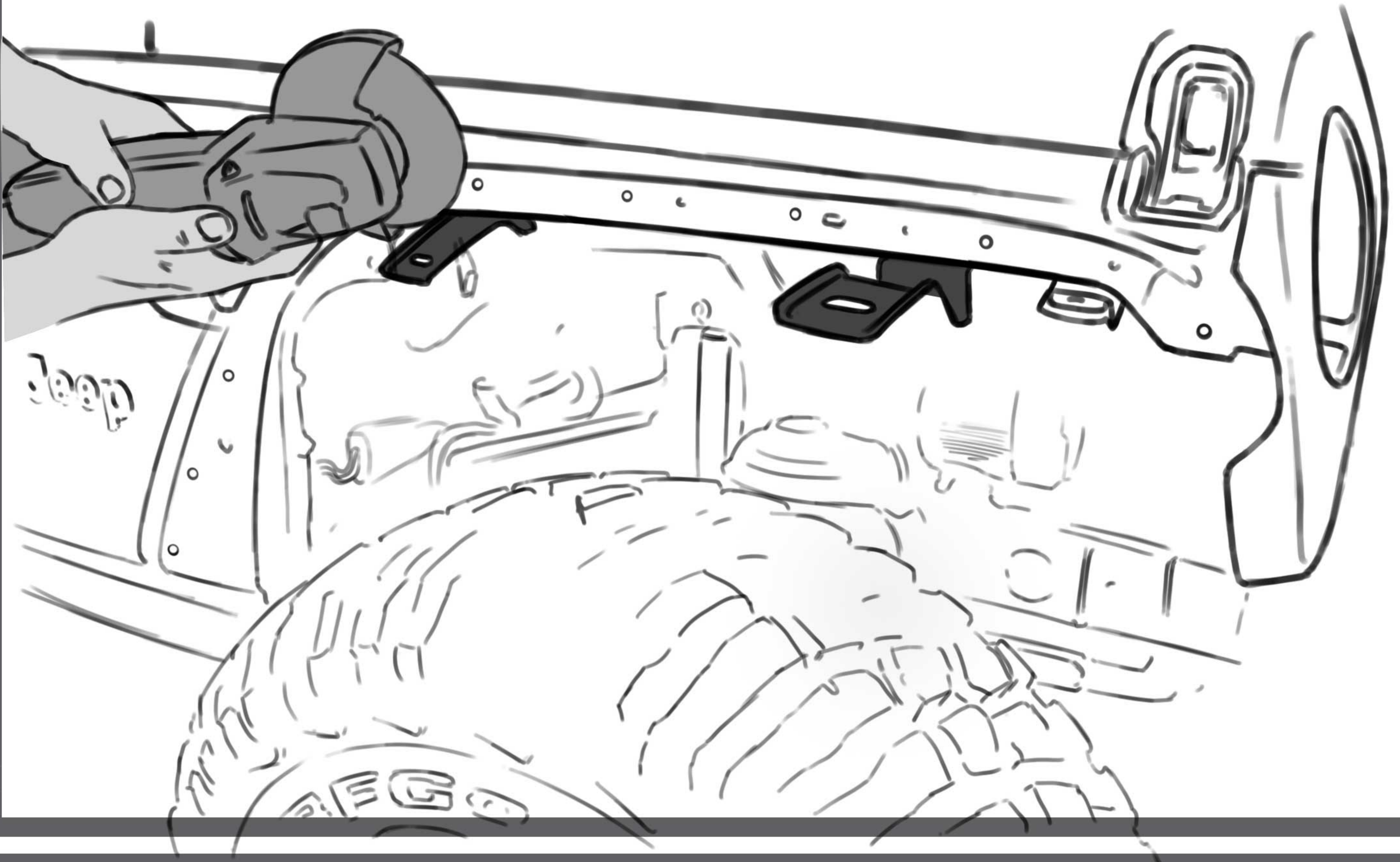

4.







# SETTING UP NEW FIXING POINTS EINZIEHMUTTERN ANBRINGEN

5.

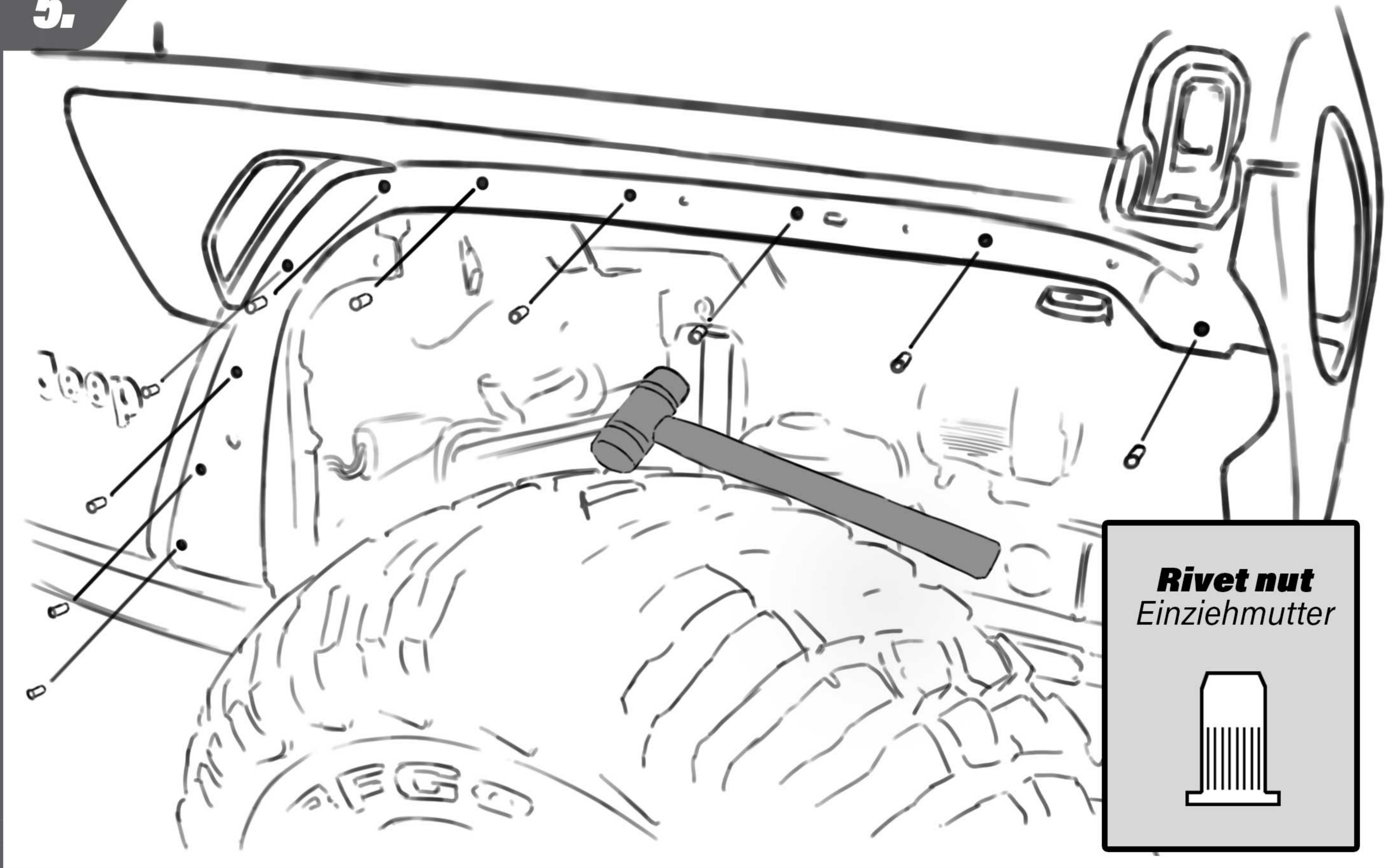

6.

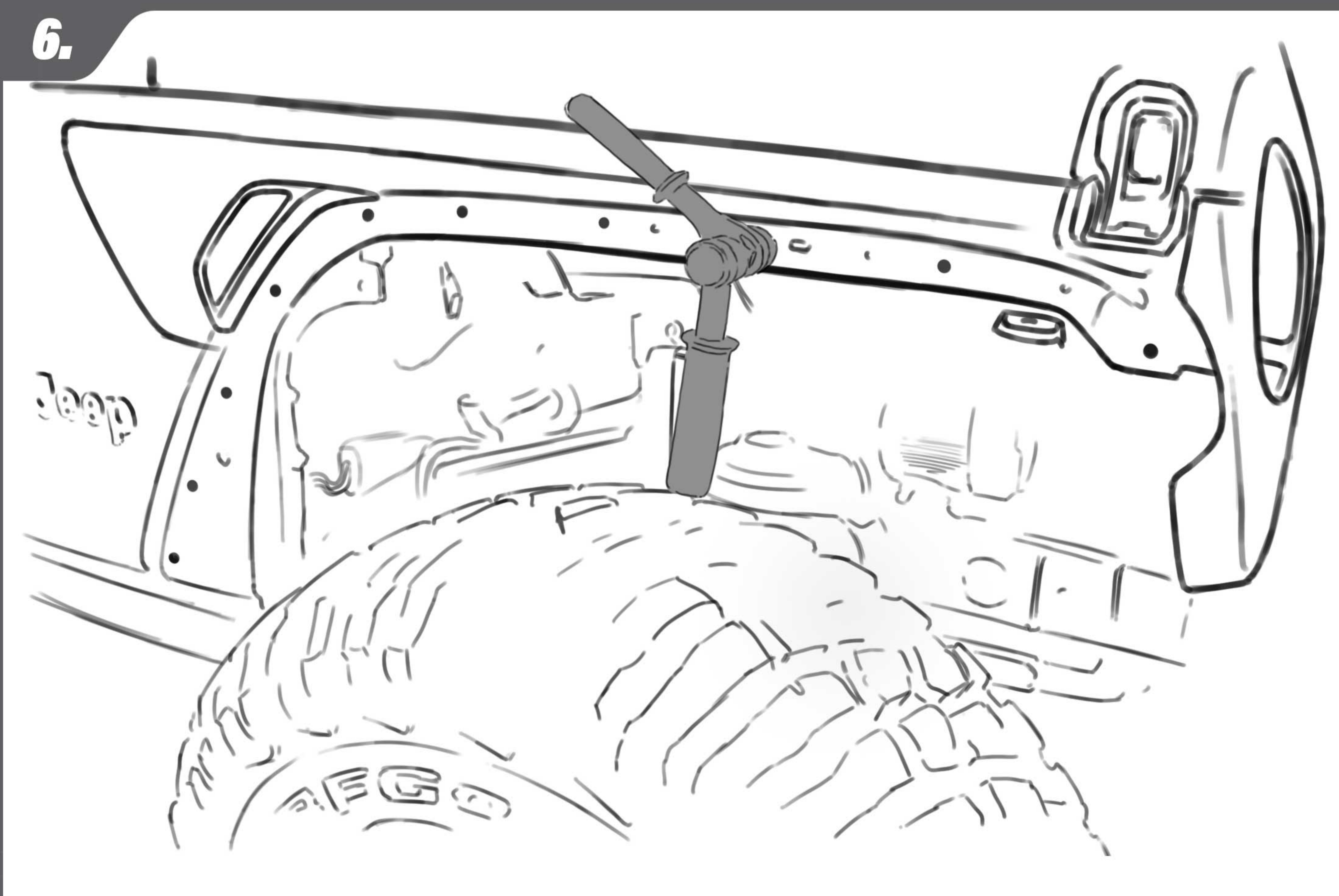





# APPLYING THE ADHESIVE TAPE ANBRINGEN DES KLEBEBANDES

7.

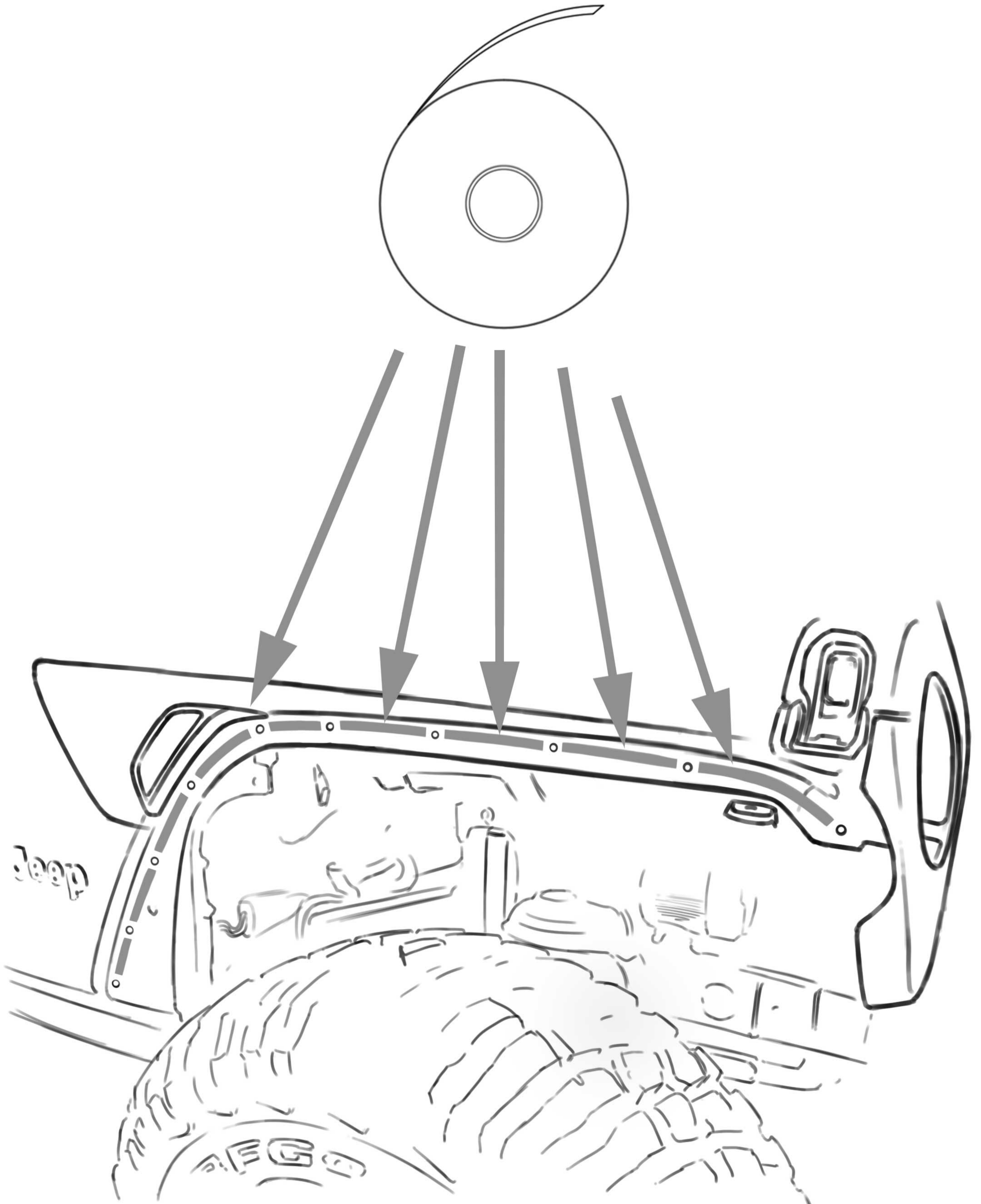





# ADJUSTING THE ORIGINAL INNER FENDERS ANPASSEN DER ORIGINAL INNENKOTFLÜGEL

8.

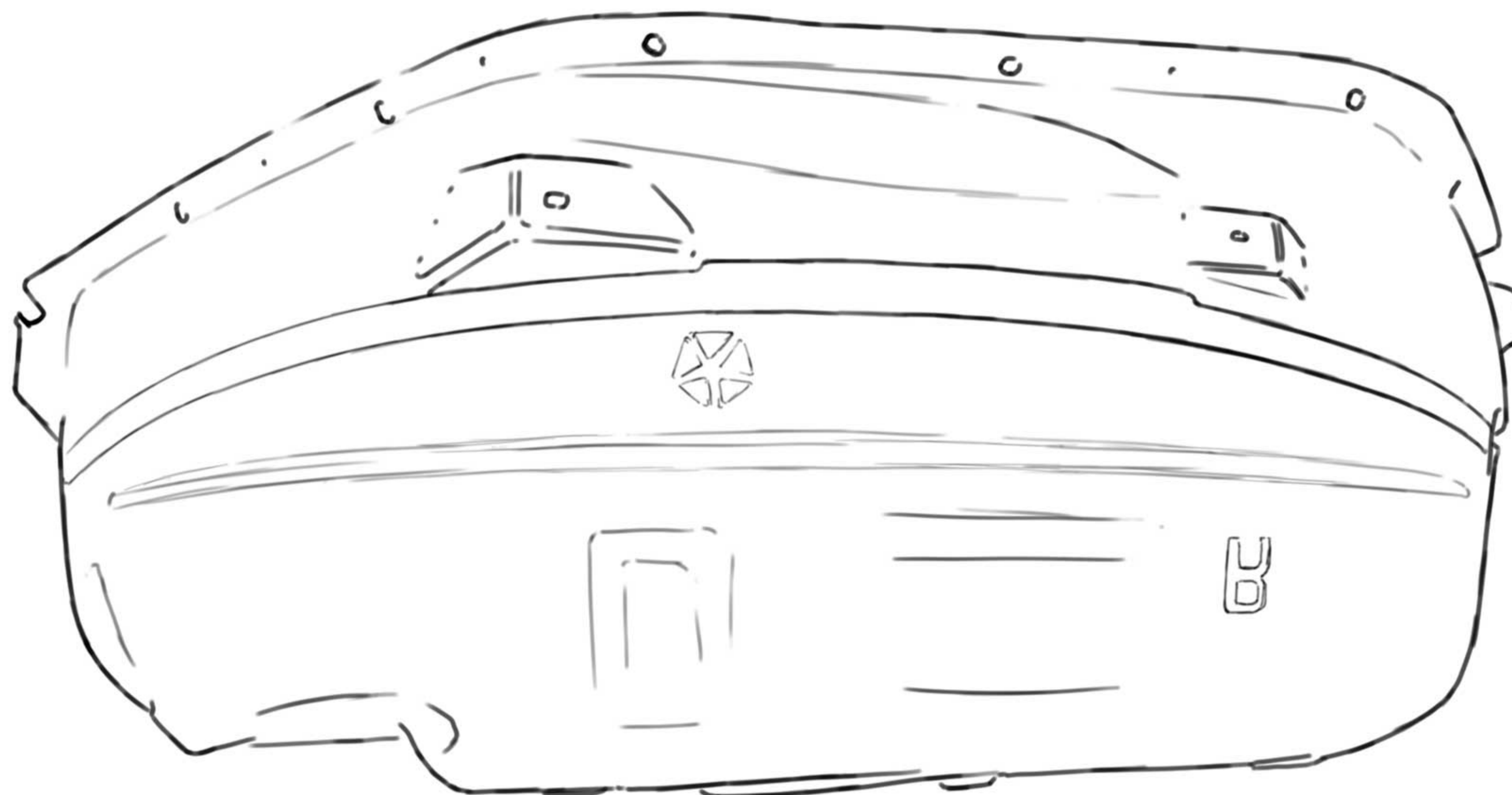

9.

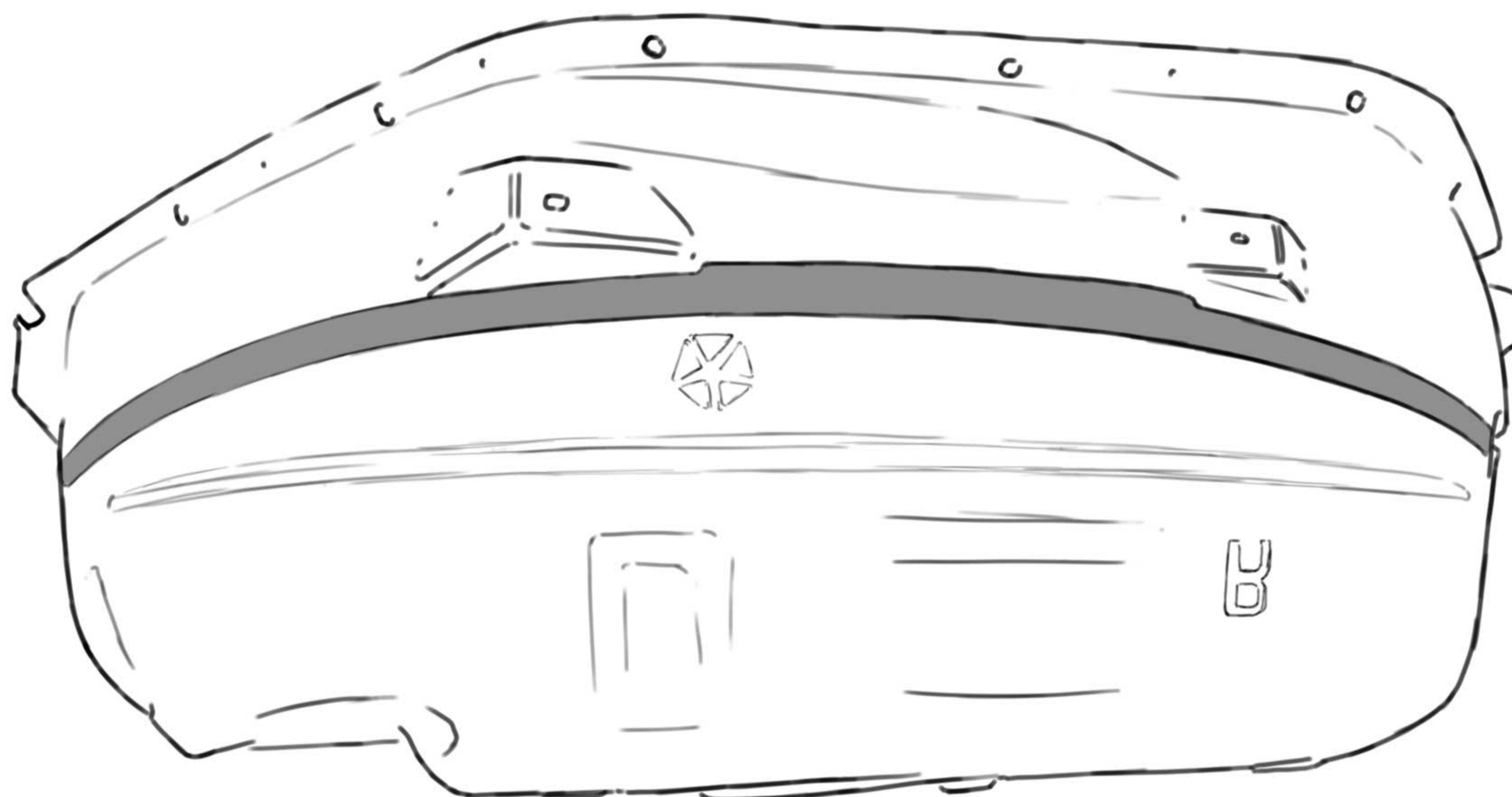

10.

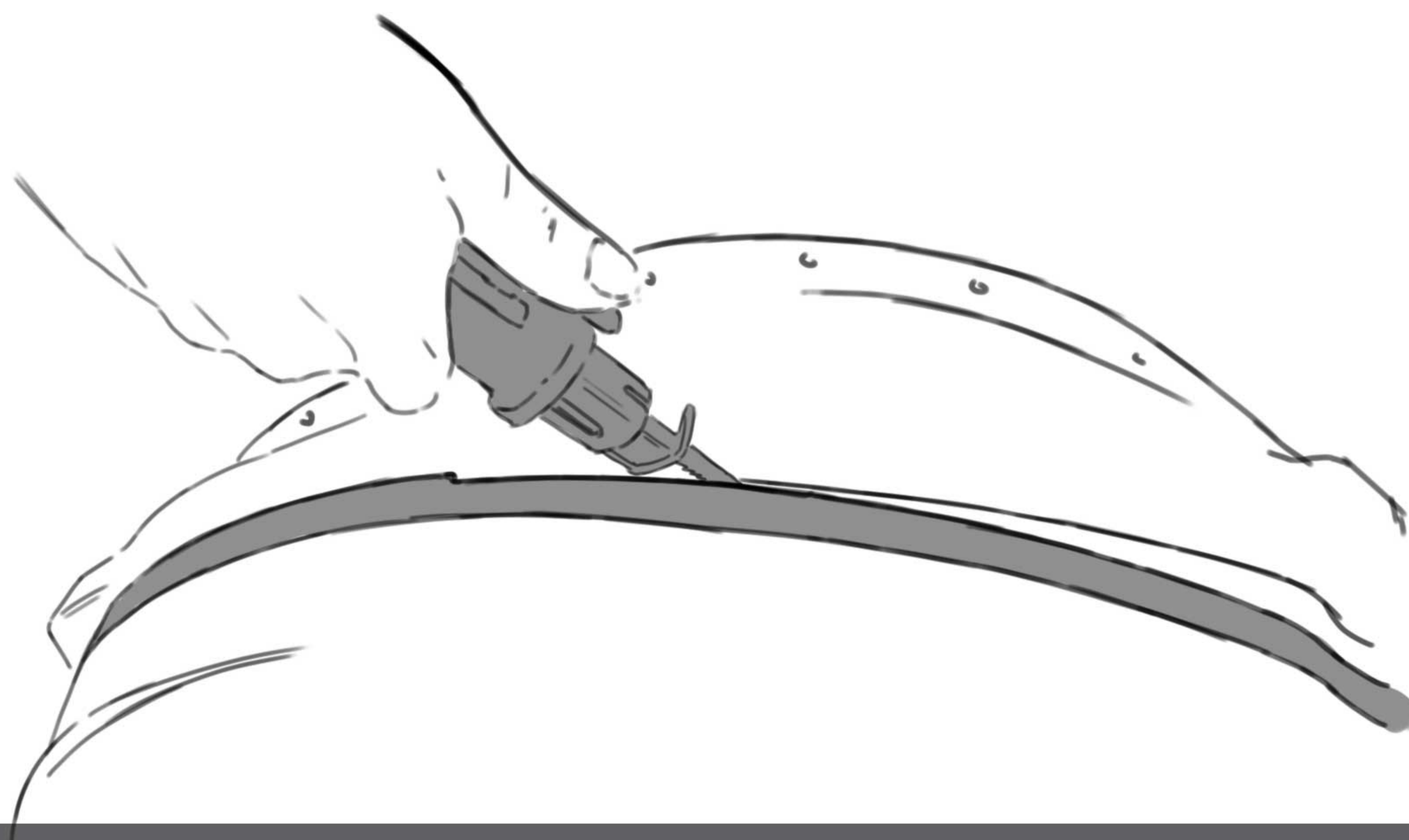





# REMOVING INNER STOCK WHEEL ARCHES ABBAU DER INNEREN OEM KOTFLÜGELN

11.

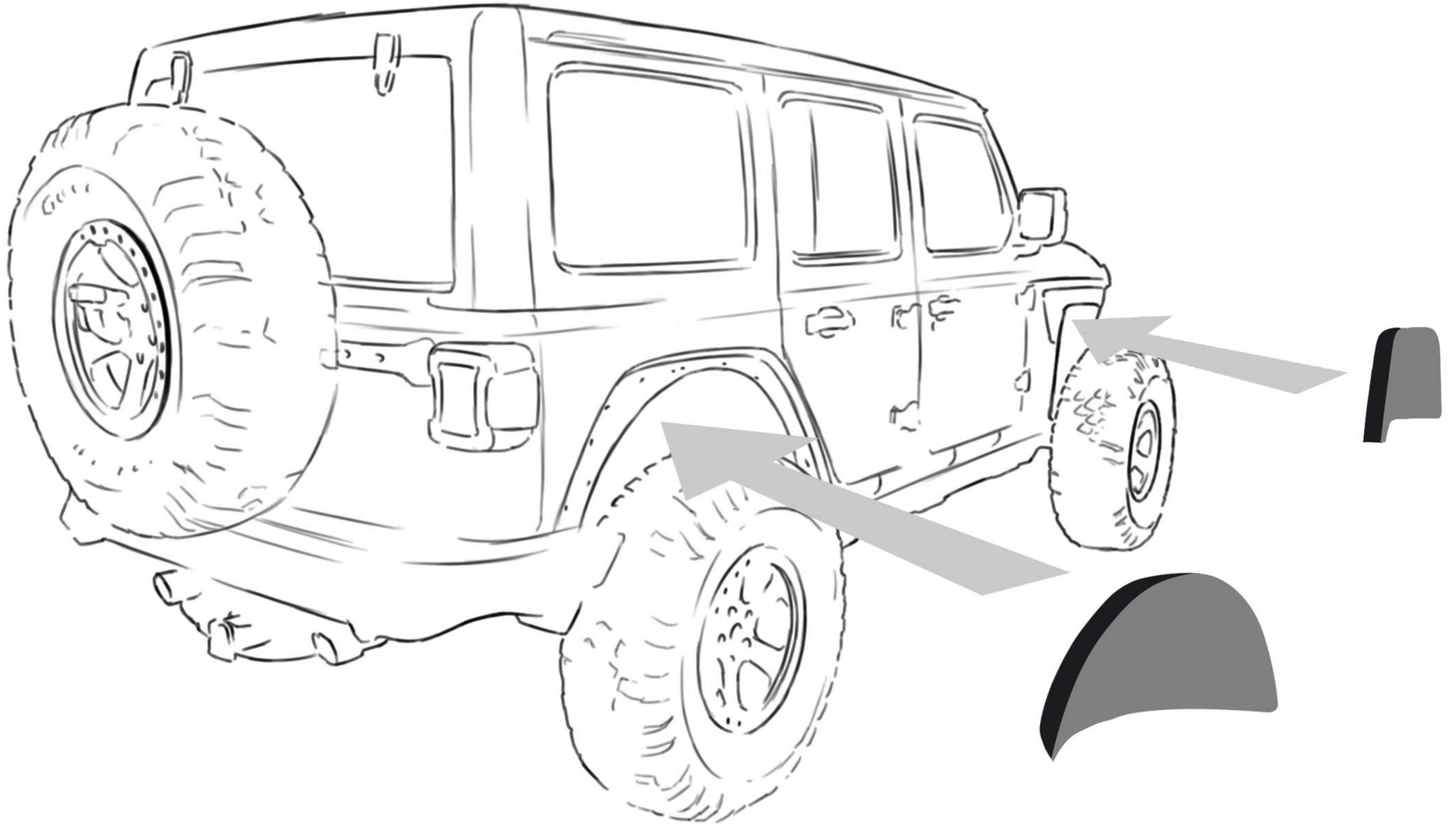

12.

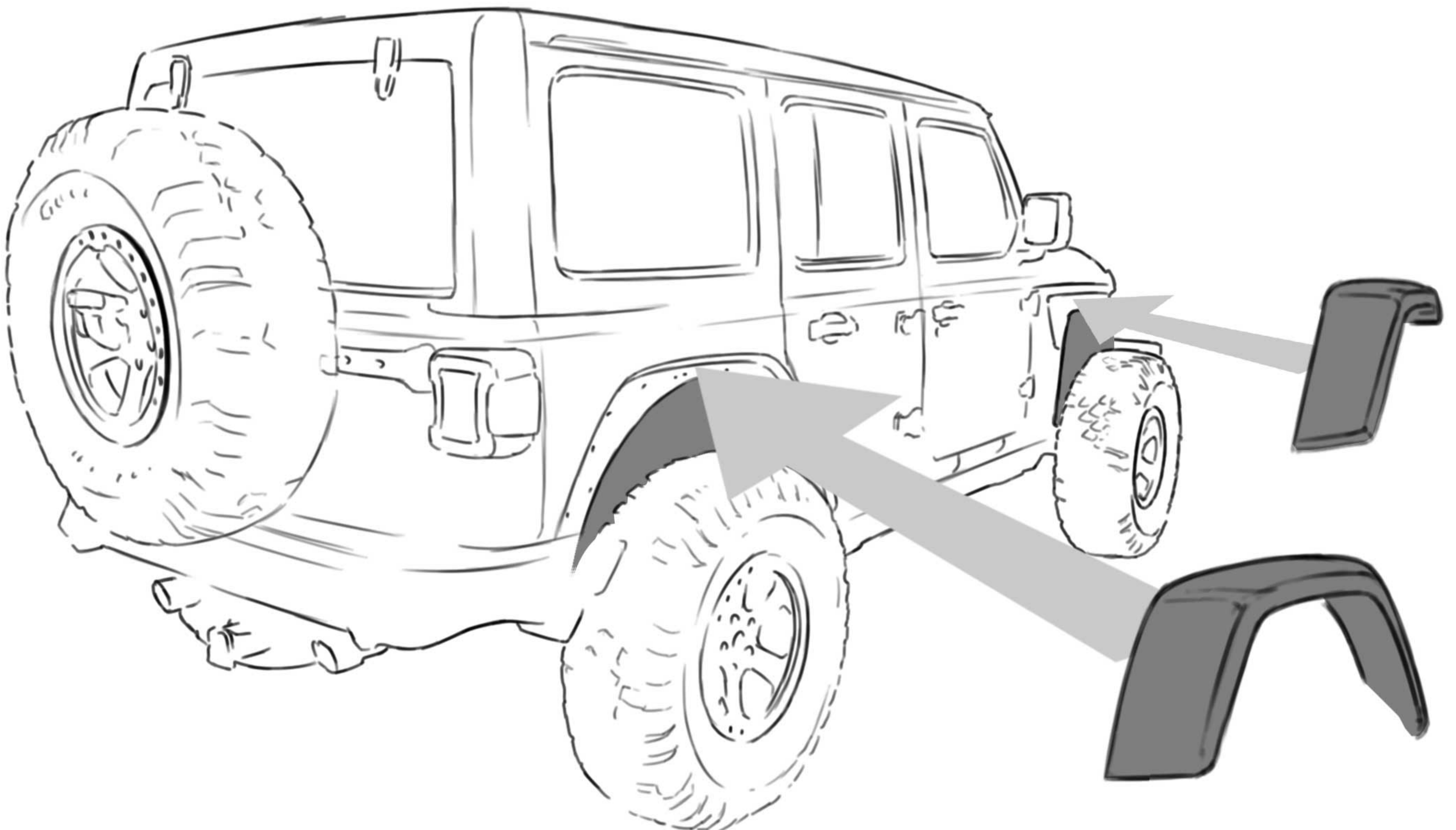





# MOUNTING X-TENDER FENDERS ANBAU DER X-TENDER KOTFLÜGELN

13.

**D**  **10x M6x20**

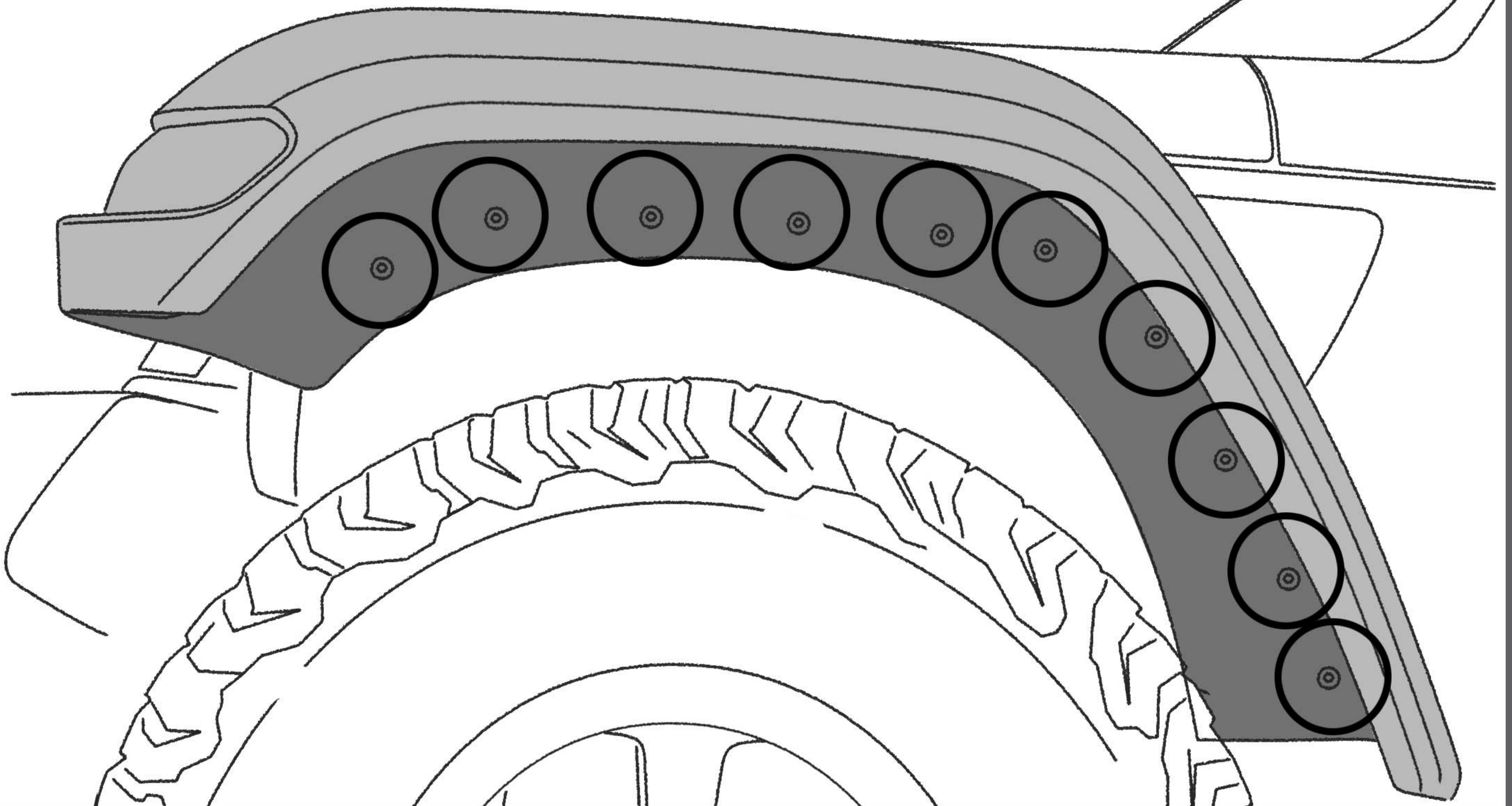

14.

**D**  **14x M6x20**

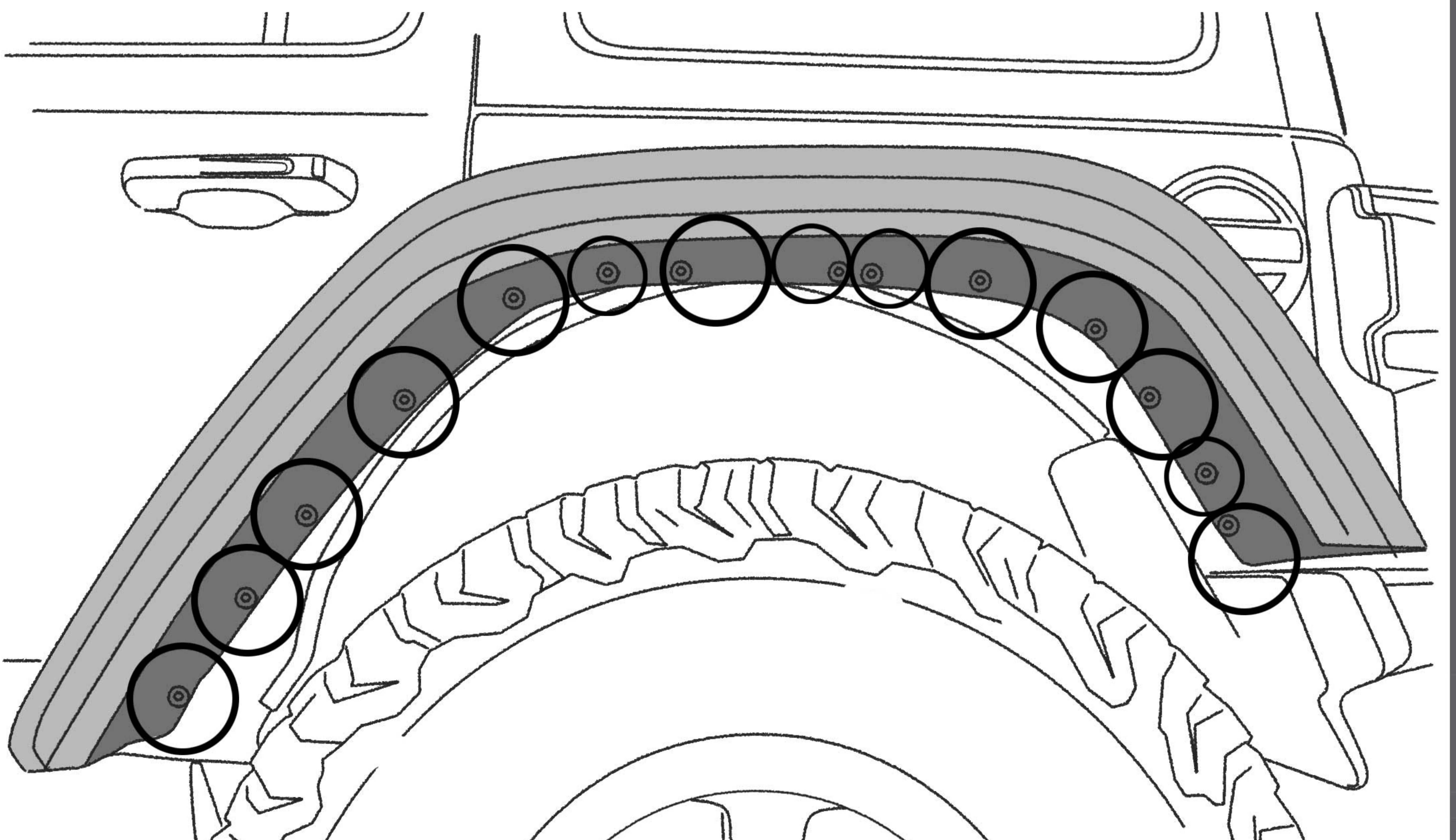





# REMOVING STOCK WHEEL ARCHES ABBAU DER OEM KOTFLÜGELN

15.

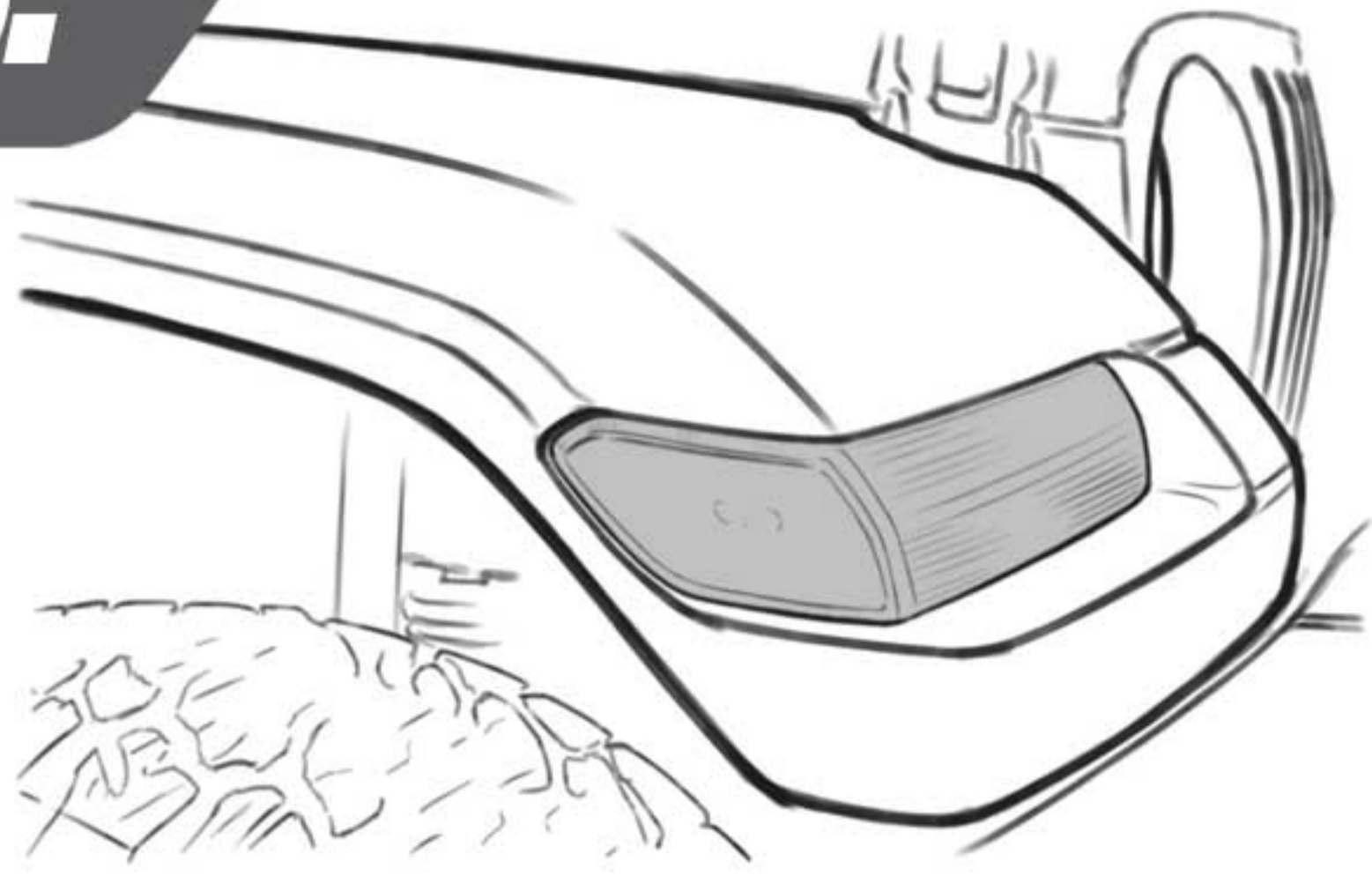

**3x** 6x16Tx30



**2x** M6x30 SW10



**2x** M6 (Bolt / Mutter)

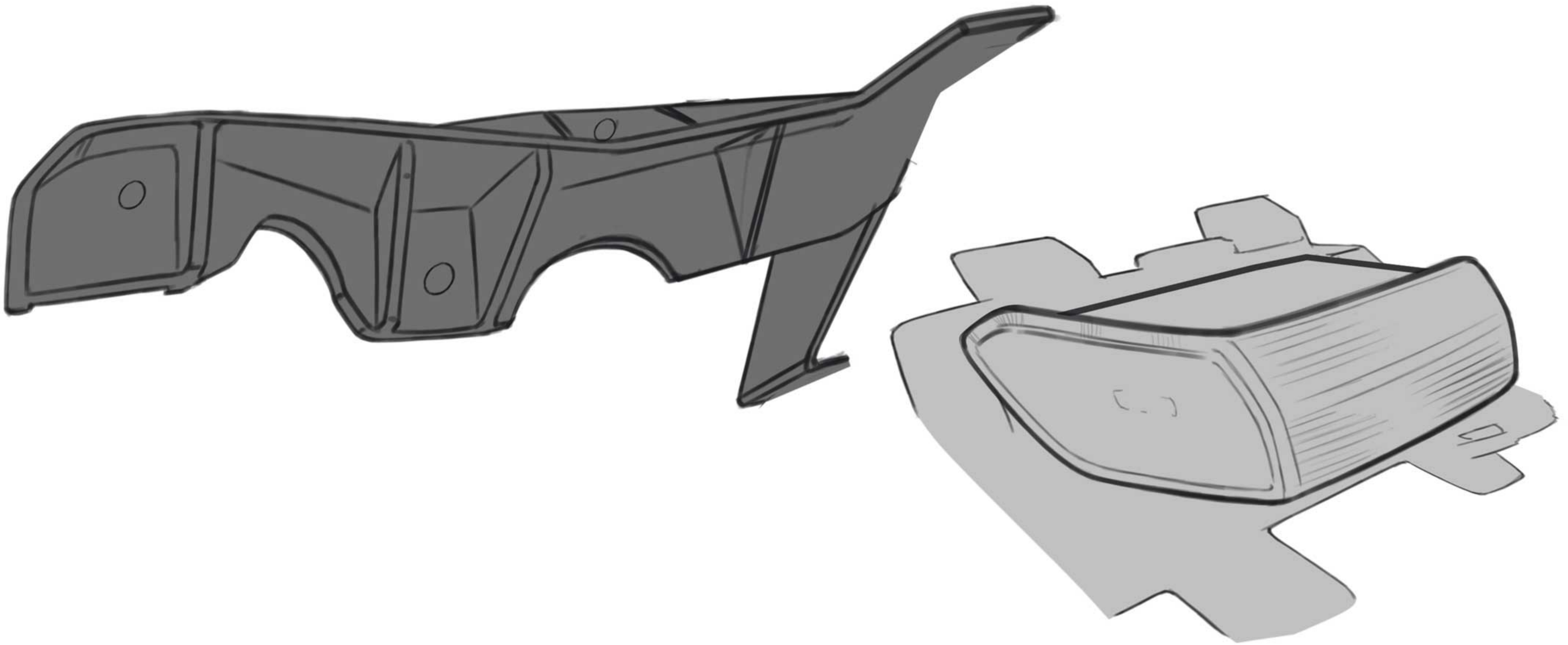

16.

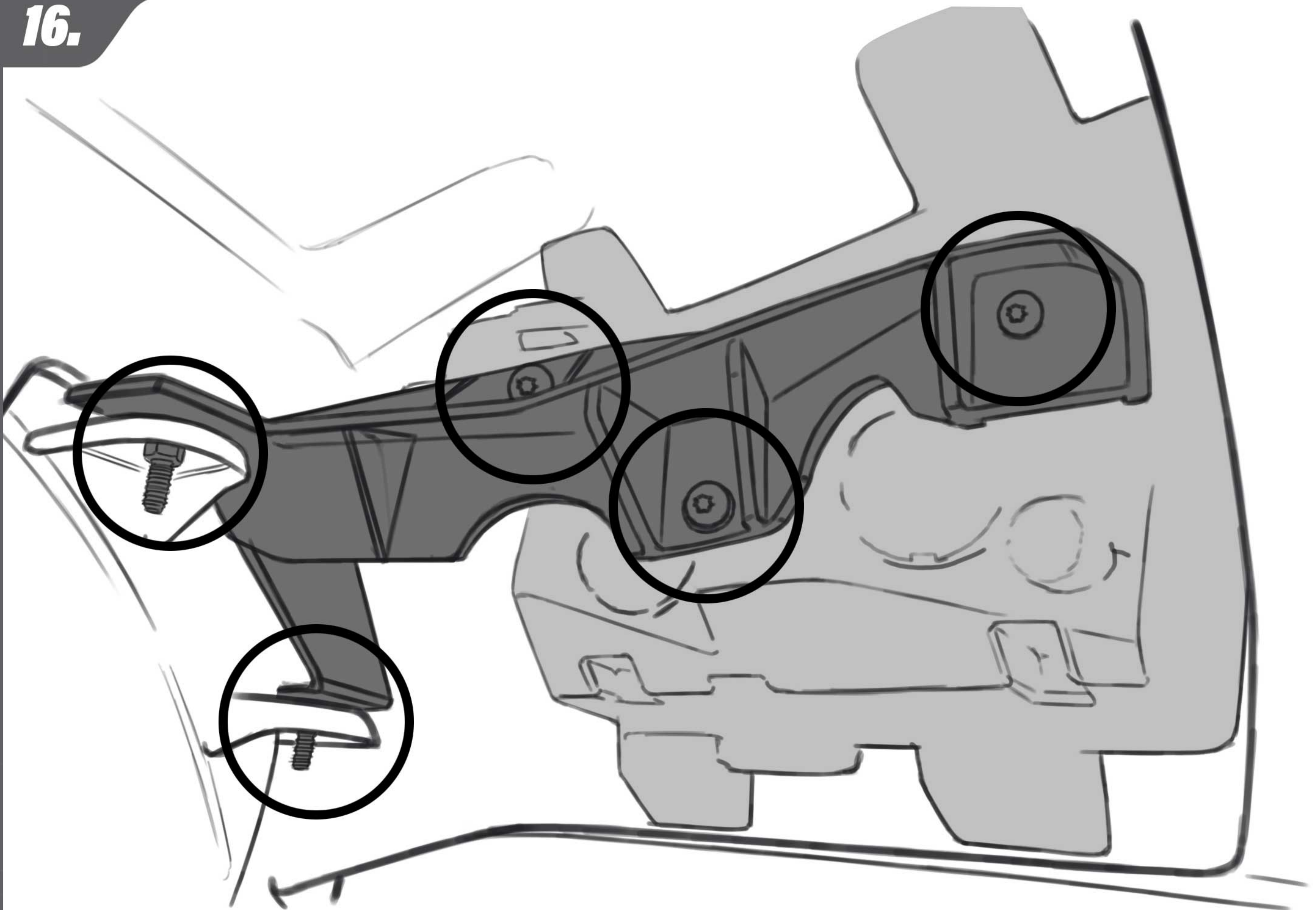





# GLADIATOR - PRECARIOUS REWIRING GLADIATOR - UMLEITUNG DER KABEL

Extra step n.1  
JT only

## Jeep Gladiator

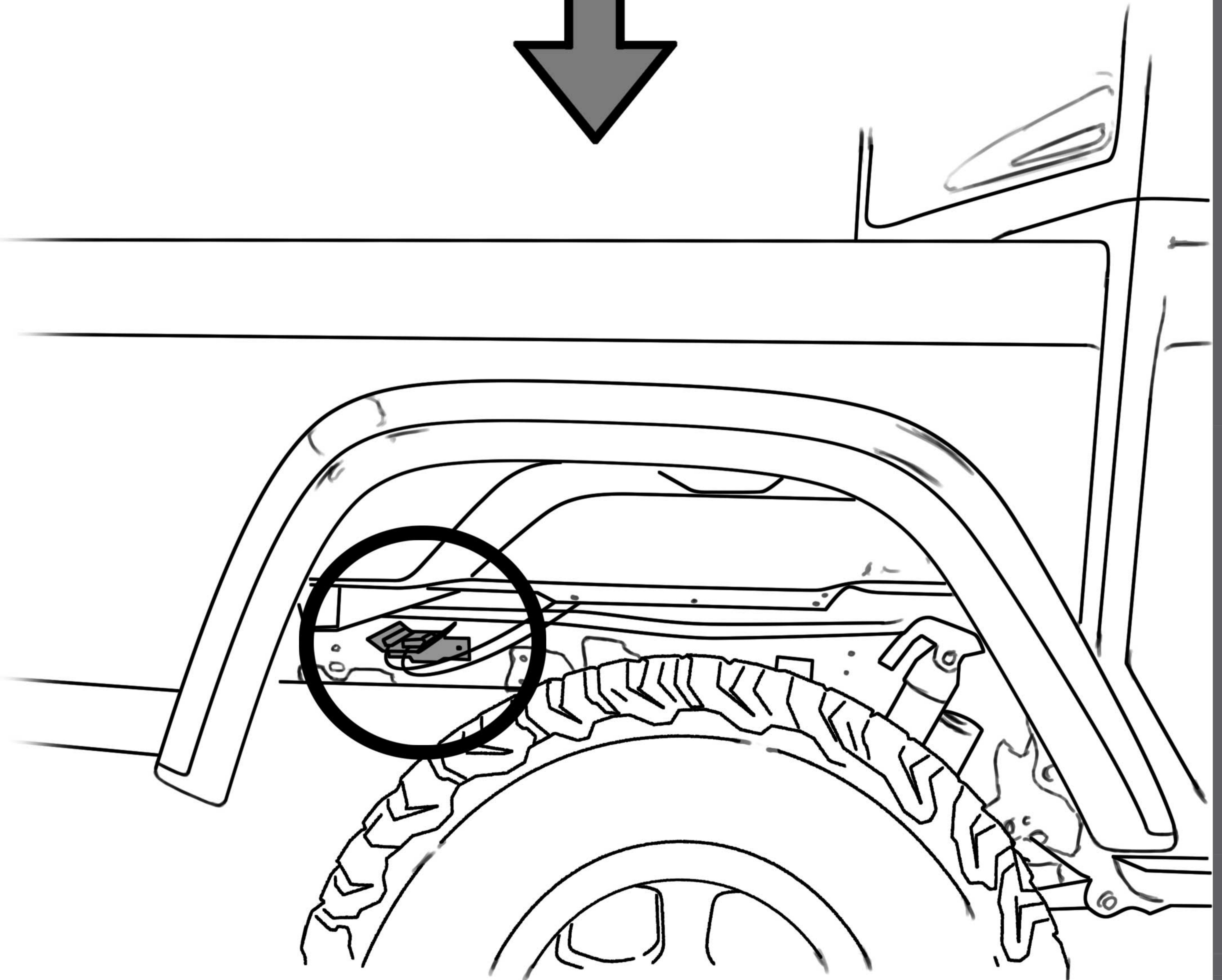
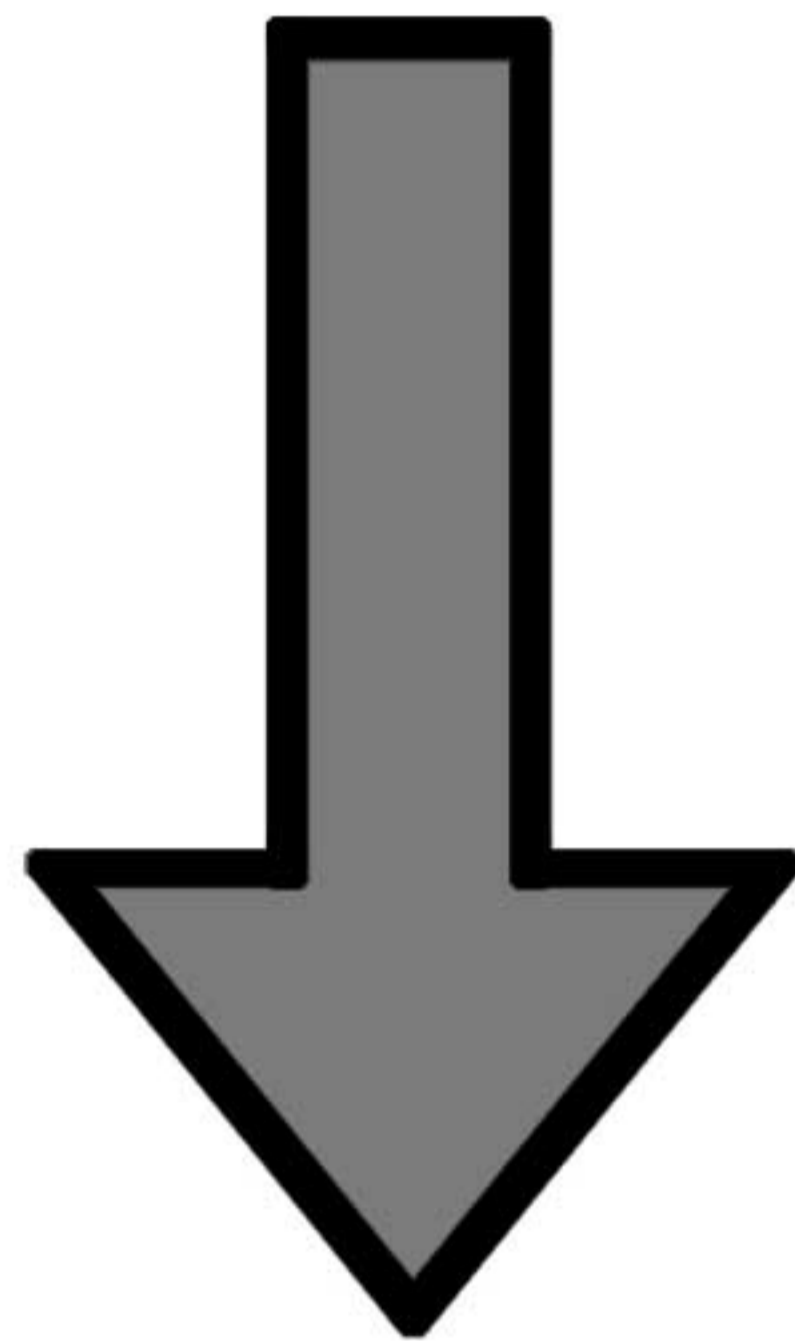





# GLADIATOR-PRÉCAUTIONS REWIRING

## GLADIATOR - UMLEITUNG DER KABEL

**Extra step n.2**  
**JT only**

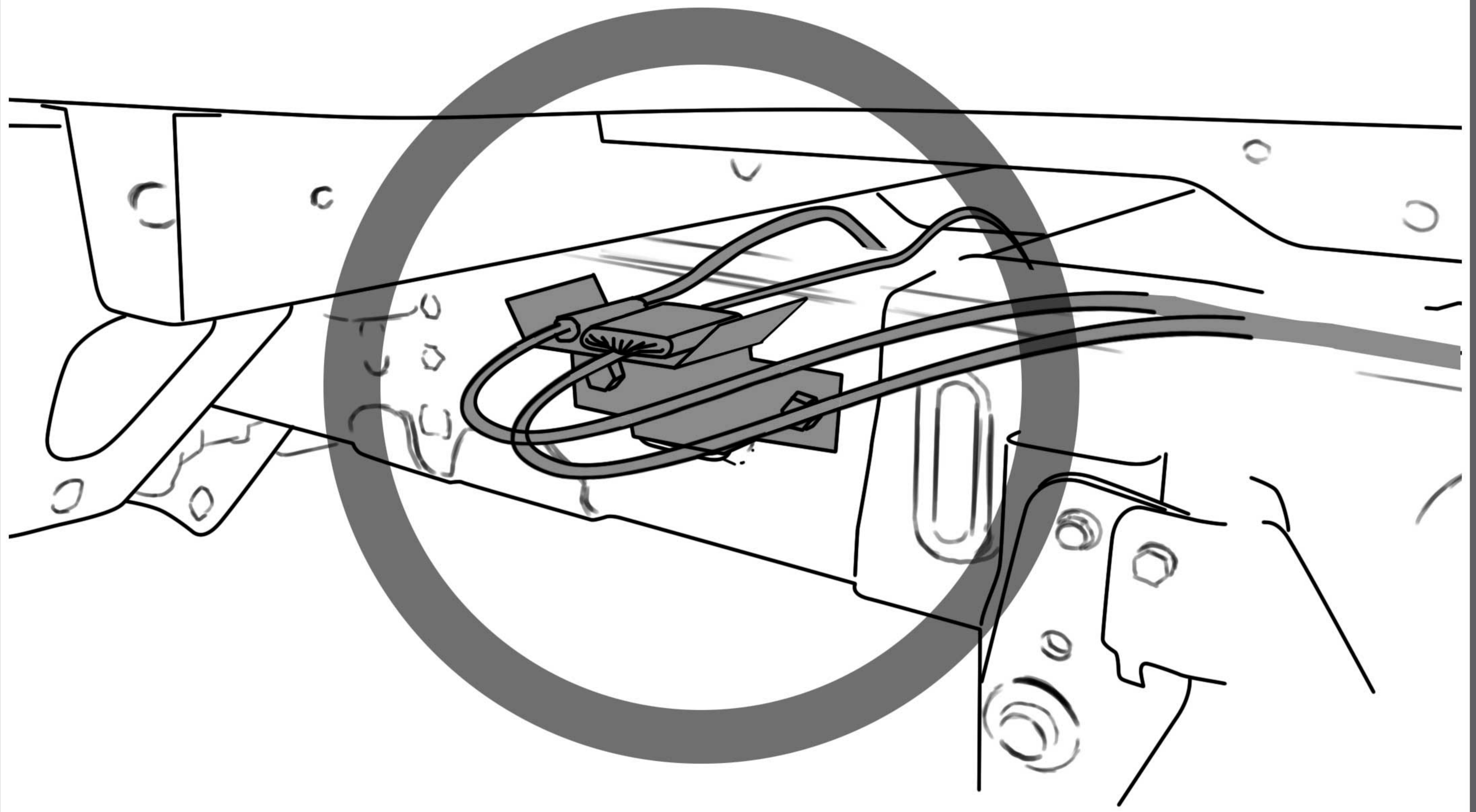

**Extra step n.3**  
**JT only**

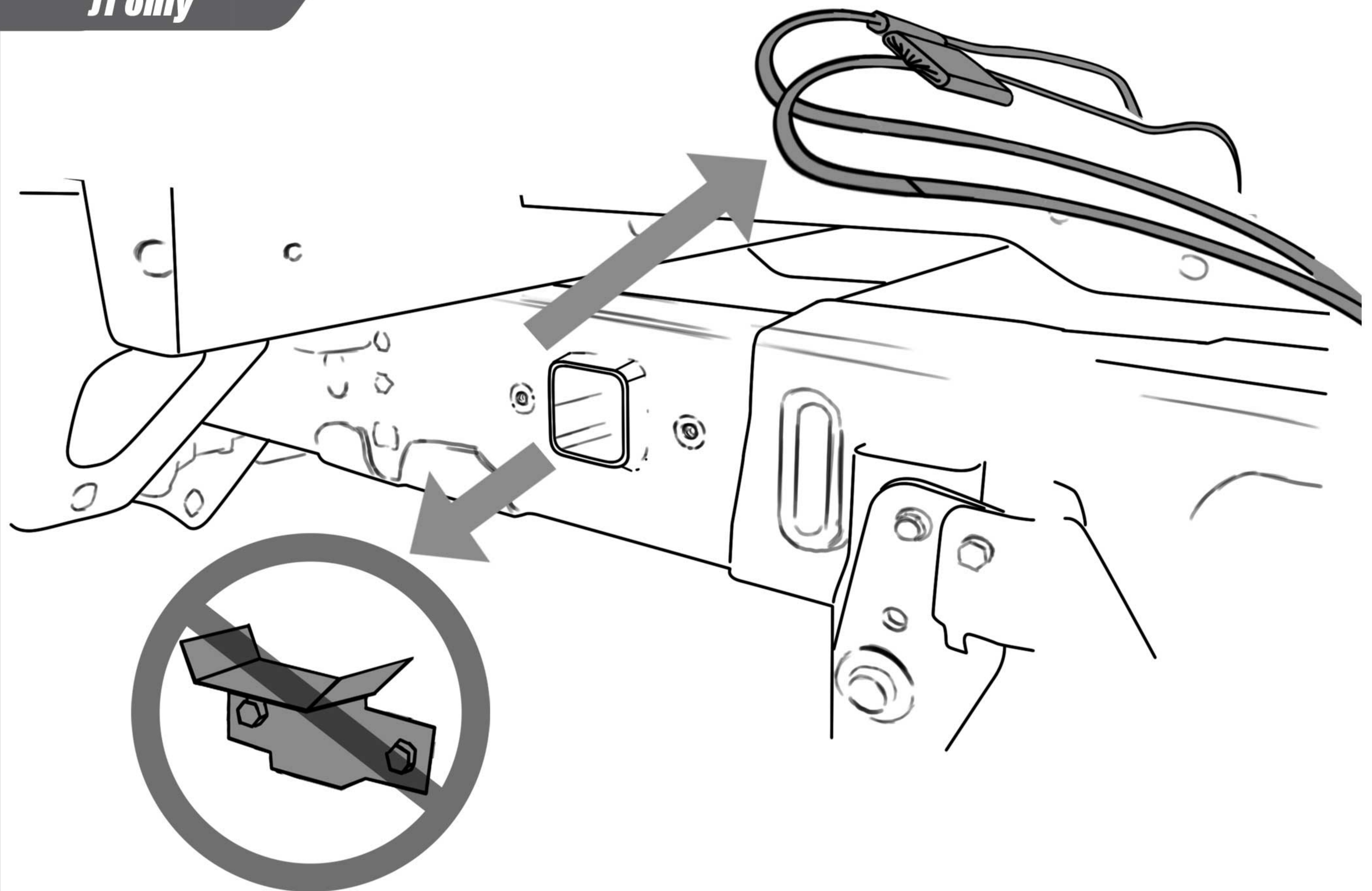





# GLADIATOR-PRÉCAUTIONS REWIRING

## GLADIATOR - UMLEITUNG DER KABEL

**Extra step n.4**  
**JT only**

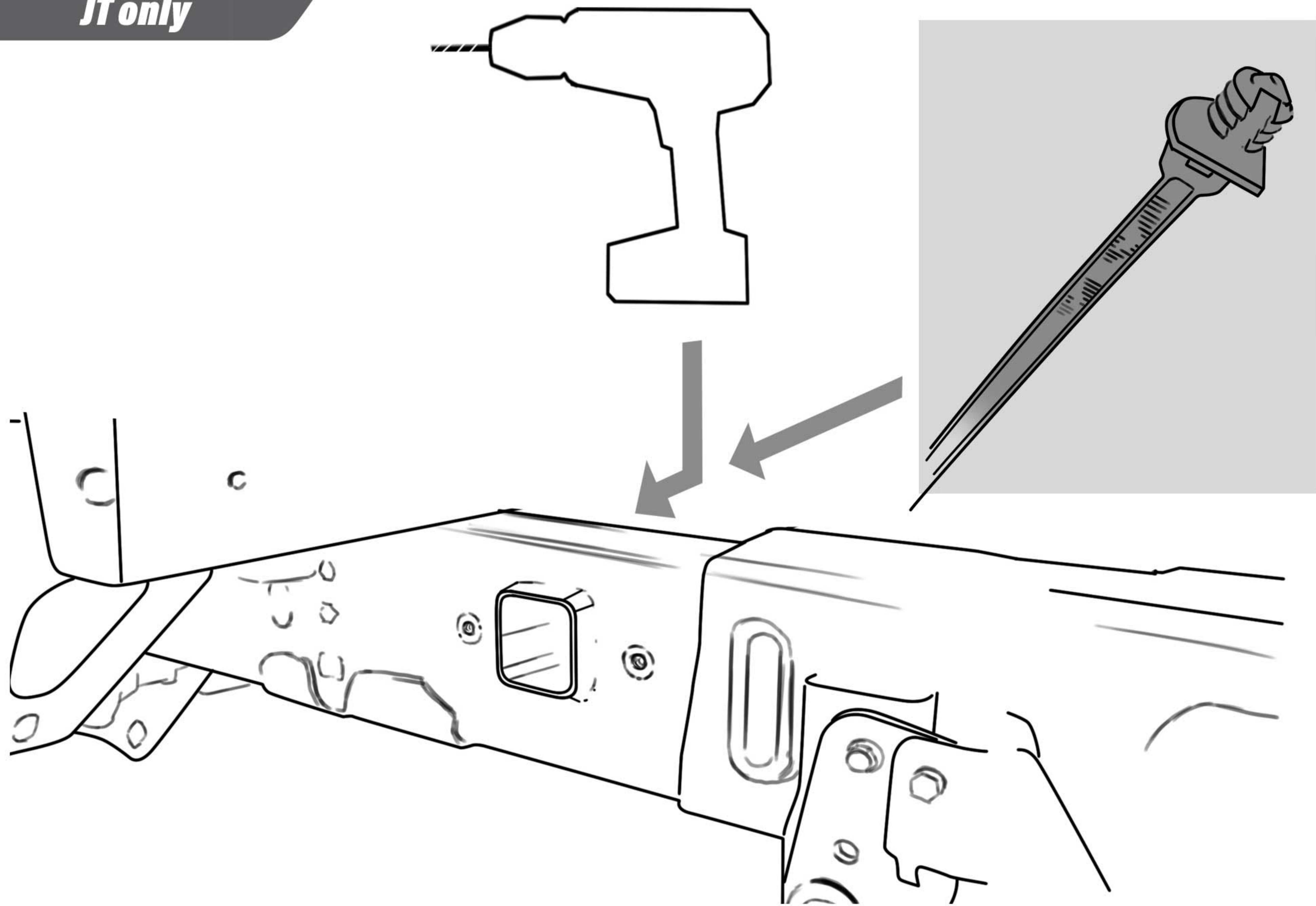

**Extra step n.5**  
**JT only**

